

# **EZ SCAFFOLD HYDRAULIC MAST CLIMBER TWIN TOWER SAFETY & INSTALLATION**

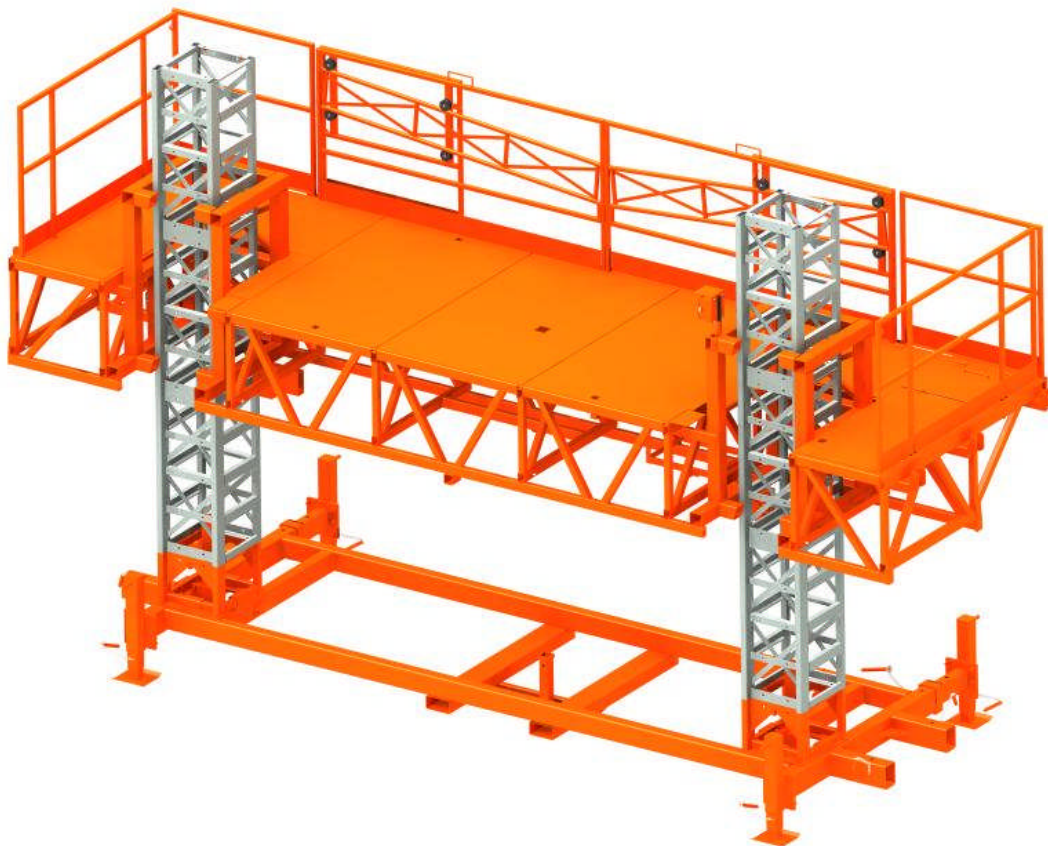

**COLUMBIA, TN 38401**

**1-800-699-6831**

**WWW.EZSCAFFOLD.COM**

THIS DOCUMENT CONTAINS PROPRIETARY AND CONFIDENTIAL INFORMATION. THE DOCUMENT AND INFORMATION ARE THE PROPERTY OF EZ DISTRIBUTING INC.. THE INFORMATION CONTAINED HEREIN SHALL BE USED ONLY AS EXPRESSLY APPROVED BY EZDISTRIBUTING INC..

# EZ MAST CLIMBER SAFETY AND INSTALLATION

**Unloading-** Always pick up by forklift receivers, towers, or T-Bars.. **NEVER PICK UP BY PLATFORM.**

**EZ MAST CLIMBERS MUST BE PUT TOGETHER BY FACTORY CERTIFIED COMPETENT PERSONNEL.**

**Soil Bearing Capacity-** Make sure that surface capacity is sufficient to support scaffold according to the following table:

Height in Feet	Lbs per Base
Up to 50	38,000
100	43,000
150	48,000
200	53,000
250	58,000
300	63,000
350	68,000
400	73,000
450	78,000
500	83,000

Heights of over 50 feet require third jack under tower.

Check for any obstructions that may interfere with scaffold assembly (electrical lines and other obstructions).

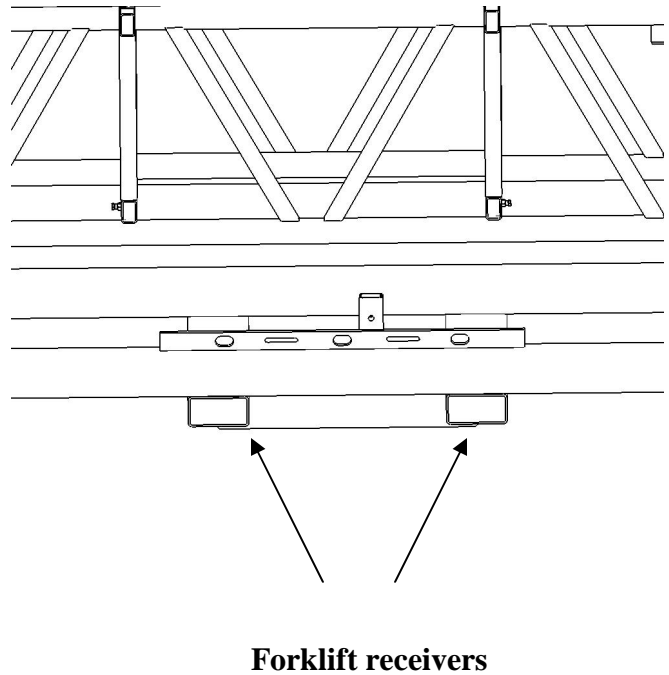

**Insert at least one tower before operation.**

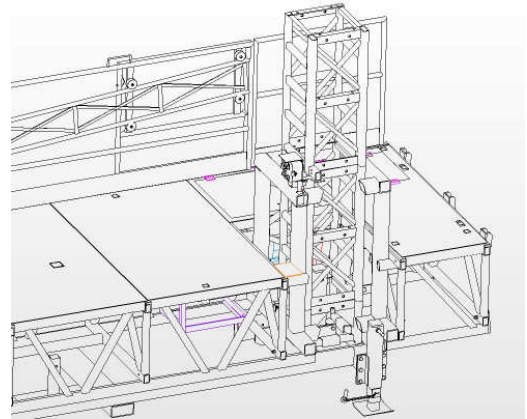

**Top out sensor-** install top out sensor on left side (left and right are viewed from material side of platform looking at the wall). Top out sensor stops platform from rising above towers.

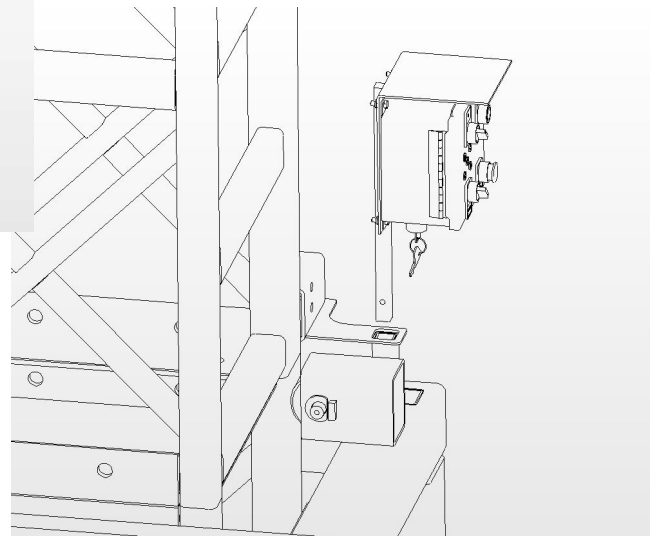
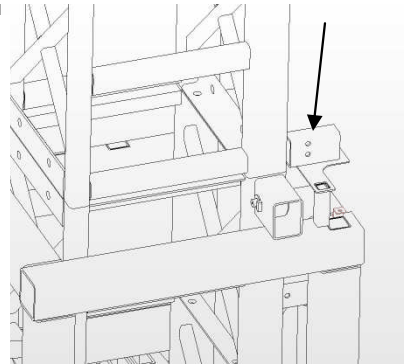

**Control Box-** connect control cable and top-out sensor cable to bottom of box. Insert box receiver.

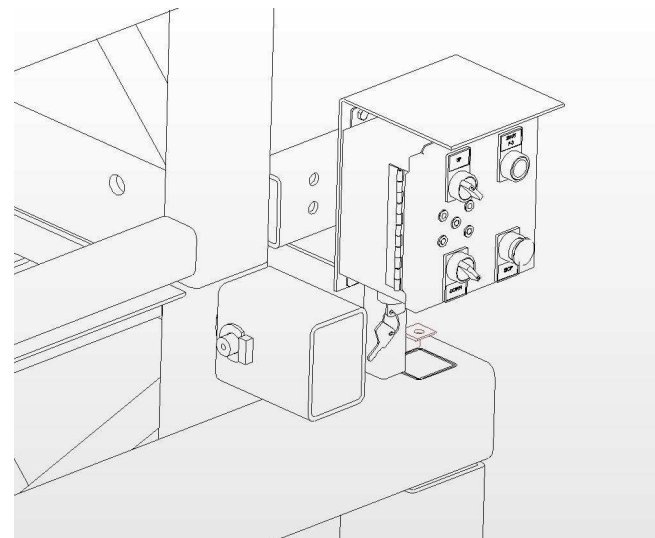

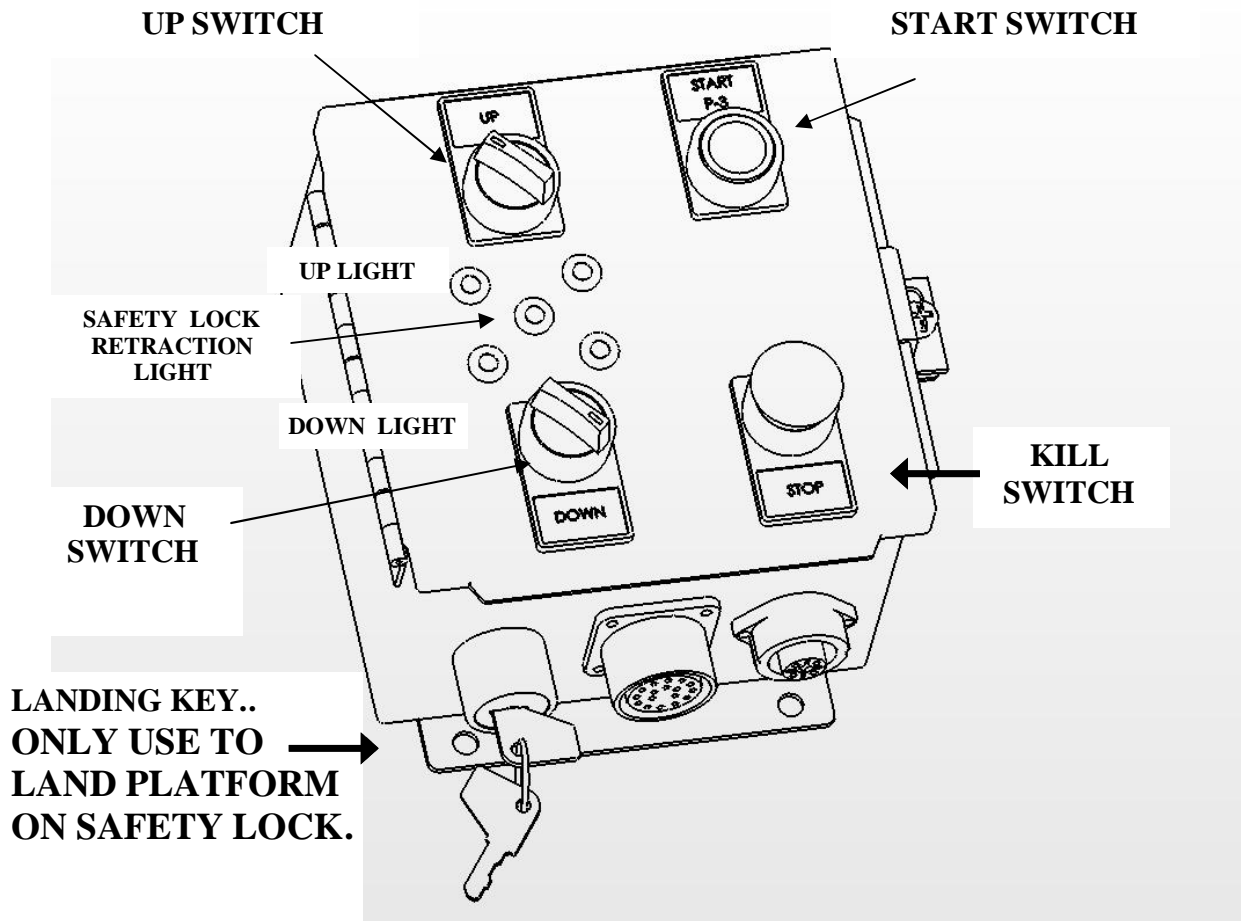

After connecting control box, turn key on at the engine. Pull out **Choke Handle** (handle is below control box). Push **Green Start Button** on control panel. Release start button as soon as engine is running. Push choke handle in.

When lights come on turn **Up Switch** (three second delay for personnel to respond to signal that platform will be moving).

**Bottom Out Sensor** - recognizes when platform is lowered as far as it can go.

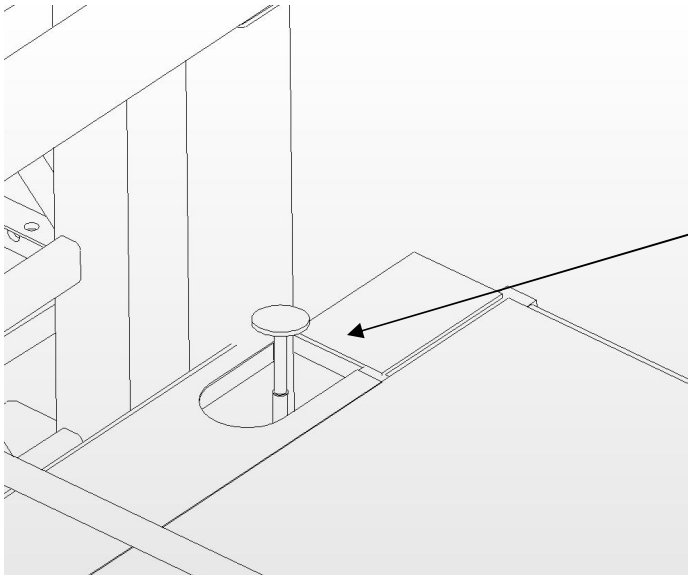
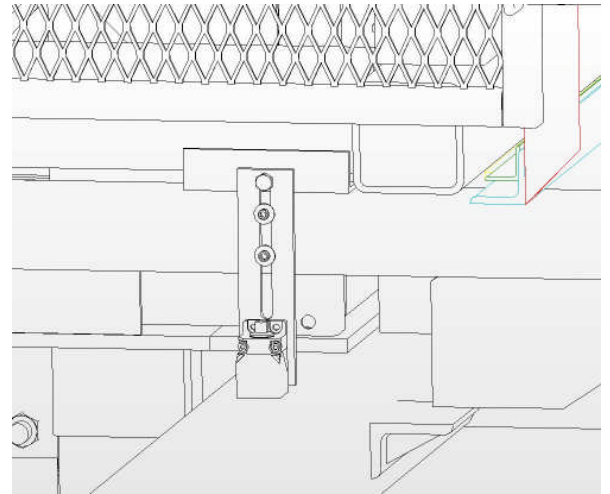

**Descent-** to descend push foot on on safety lock lever on platform next to control panel.

Turn **Down Switch** on Control Box, lights will come on (**wait for 3 second warning delay**).

**Wheel Assemblies- Platform must be raised above height of wheels to insert wheel assembly.**

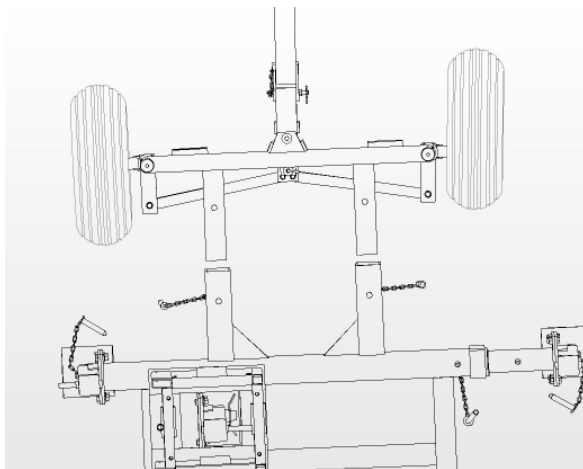
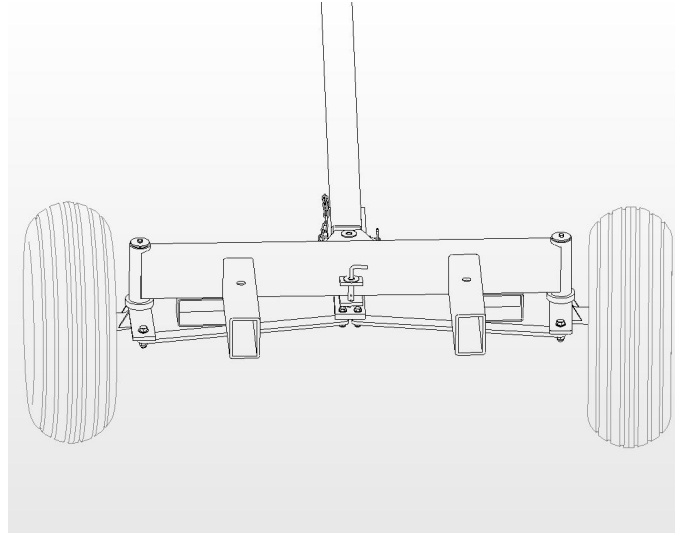

**Insert wheel assembly into receivers on base unit.**

**Insert pins into holes in wheel assembly and receiver.**

**\*\*\*Unit is not to be towed faster than six miles per hour\*\*\***

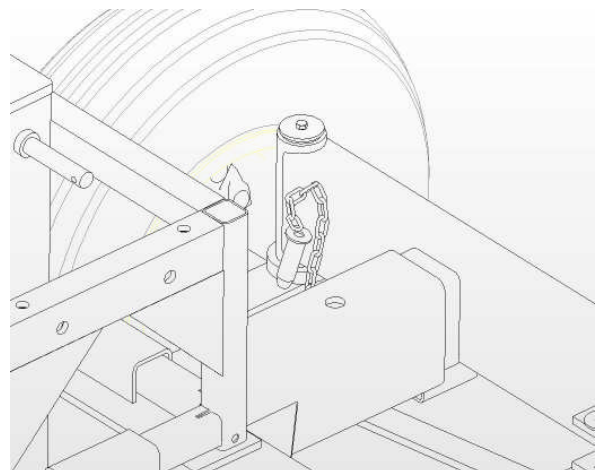

## POSITIONING AND LEVELING

Allow for Cantilever Decks and Corner Brackets when determining where Power Unit is to be set.

Make sure ground where adjustable legs are to be set is level and clear of debris.

Set Mud Sills (cribbing, leveling blocks) if necessary. Cribbing must meet OSHA specifications.

Set Power Unit in increments of 10" from the front of the platform, up to 60" (allowing preferred distance between walkboards and wall).

Extend support legs if not tying off. If tying off, keep support legs retracted.

Adjust jack legs.

Level all four legs according to next page.

If going over 50 feet high, third jack leg under tower is necessary.

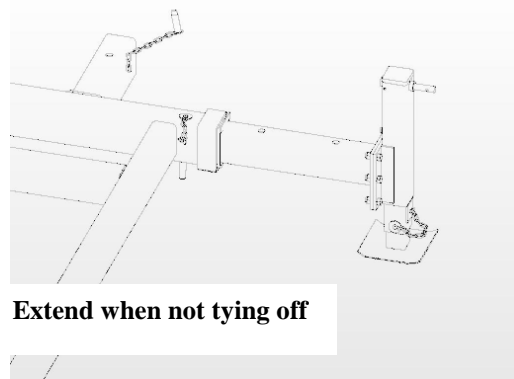
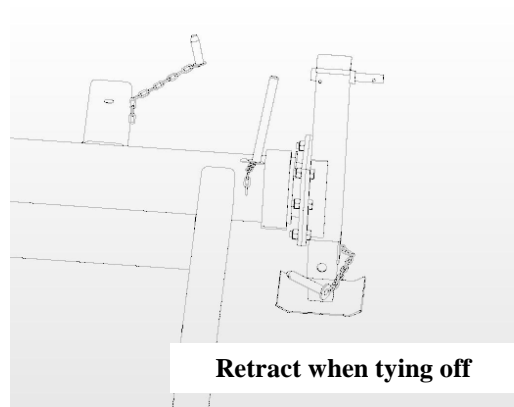

Use third jack for heights over 50'

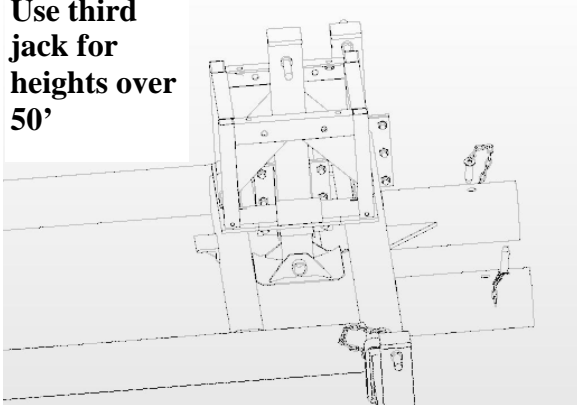

**Level base from front to back at  
jack support legs.**

**Level base from side to side.  
Check base from front of base and  
back of base.**

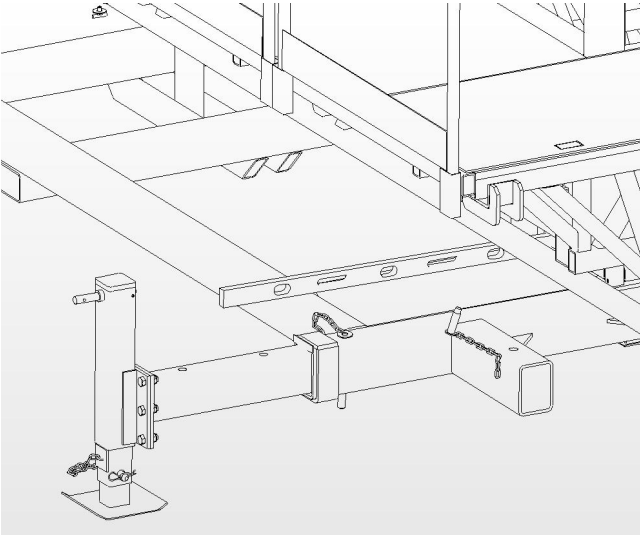
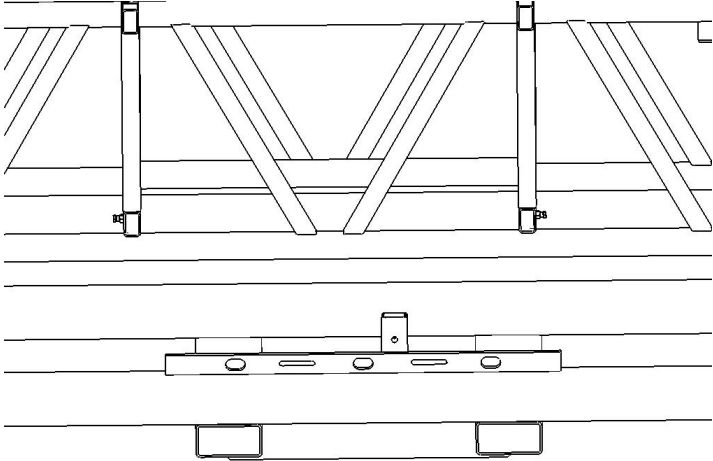



**Towers may be inserted on the ground and moved fully assembled or put on one at a time by hand at the platform.**

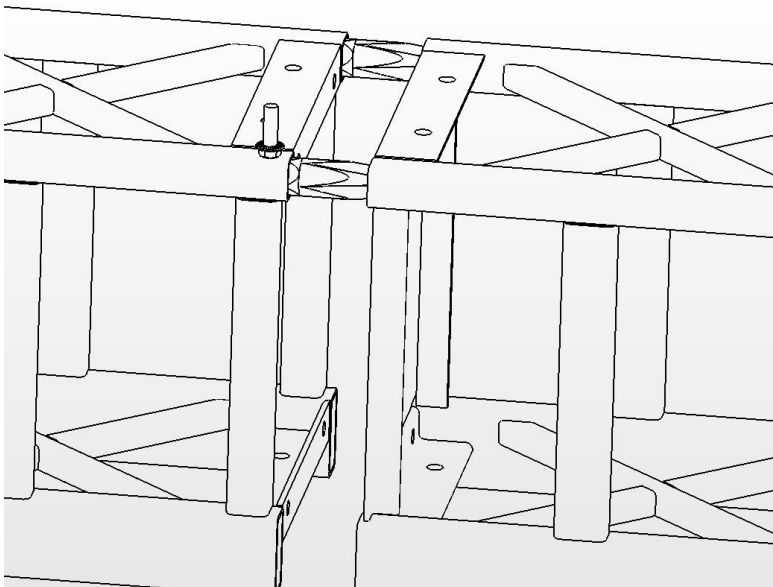
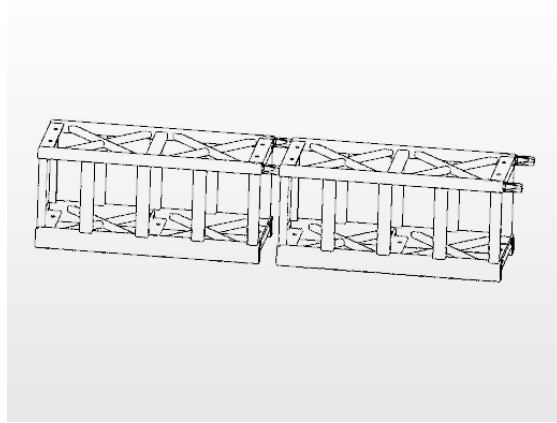

**Use grade 8 bolts provided and replace with like bolts. Tighten fully and check repeatedly during use.**

# CANTILEVER DECK

Cantilever Decks come in lengths of 4', 8', and 16'. Cantilever Decks may be used on either the right or left of Power Unit, as well as connected together. Anything less than 4' may be spanned using corner brackets.

Power Unit has three receiving hooks on each side.

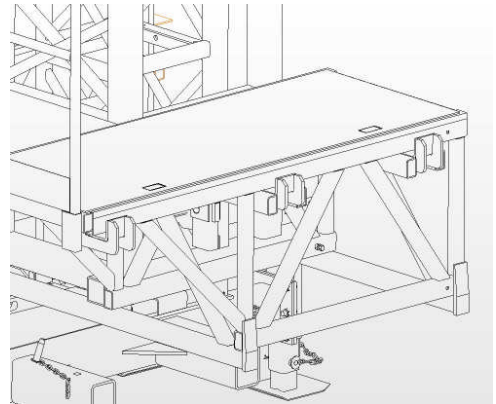
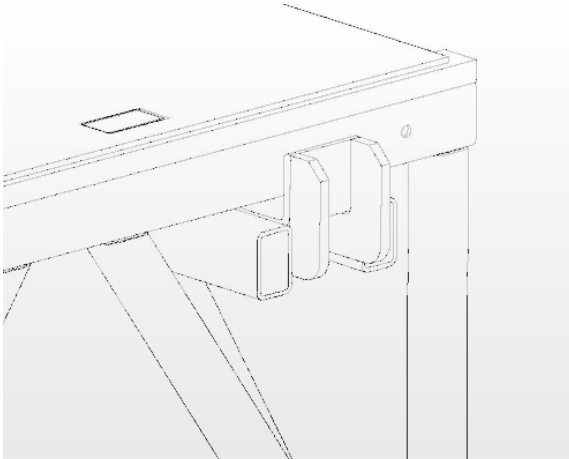

Decks may be put on using lift forks or straps. Side of Cantilever Deck connecting to Power Unit should tilt slightly lower than far side. This makes it easier for Decks to connect to hooks. Decks should be flush to Power unit on wall side. IF UNABLE TO BE DIRECTLY BEHIND PLATFORM, DO NOT USE FORK POCKETS. USE SLING PROVIDED.

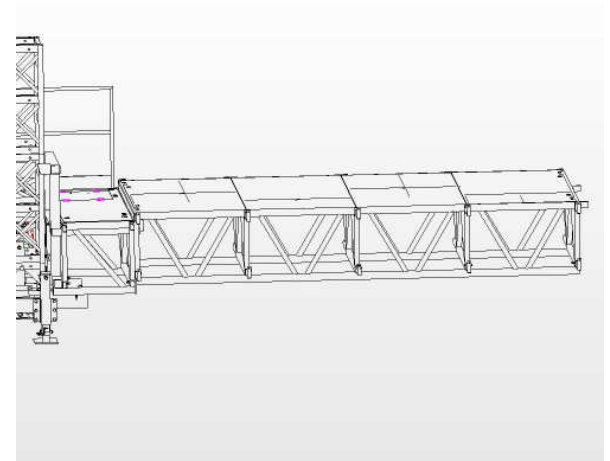

**FLUSH DECK TO  
POWER UNIT**

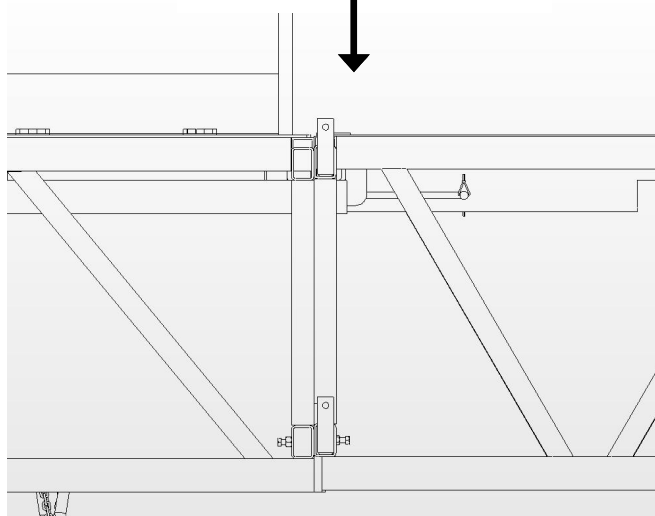

**SIDE OF DECK FACING  
POWER UNIT SHOULD BE  
LOWER THAN FAR SIDE**

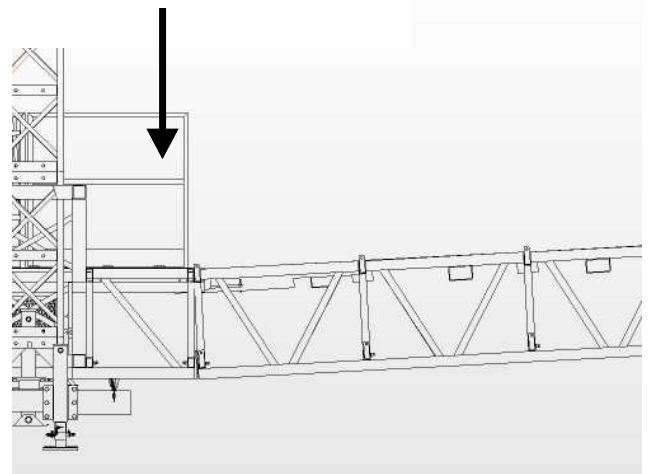

**Cantilever Decks contain slide bars. Bars must be extended under connecting platforms and pinned.**

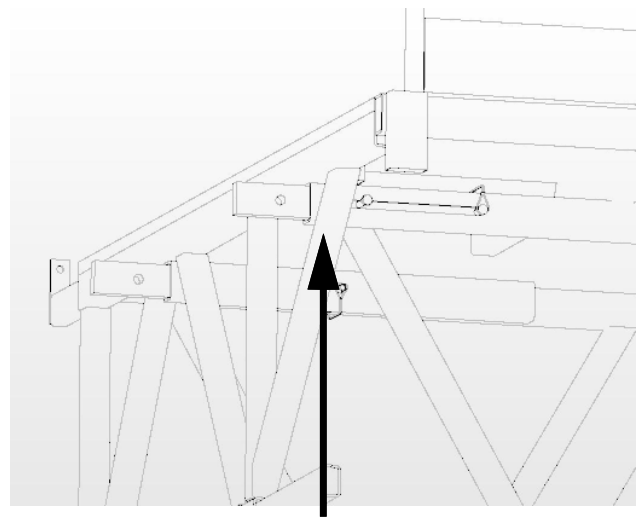

**SLIDE BAR MUST BE EXTENDED**

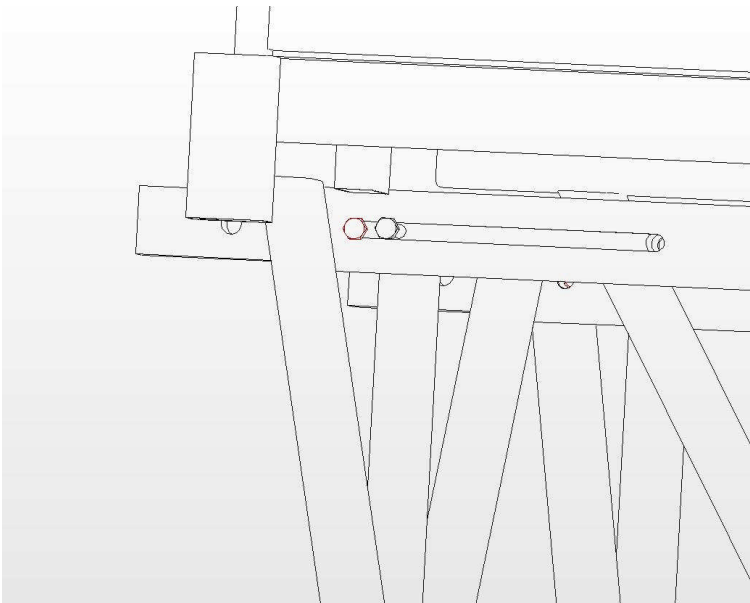

**LOCK PIN MUST BE INSERTED**

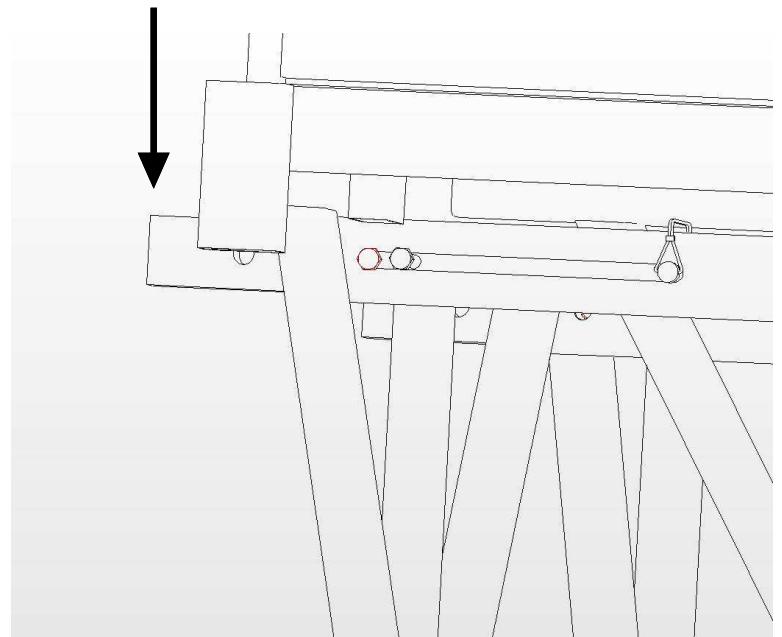

**Larger Cantilever Decks should be closest to Power Unit and smaller Cantilever Decks installed further away.**

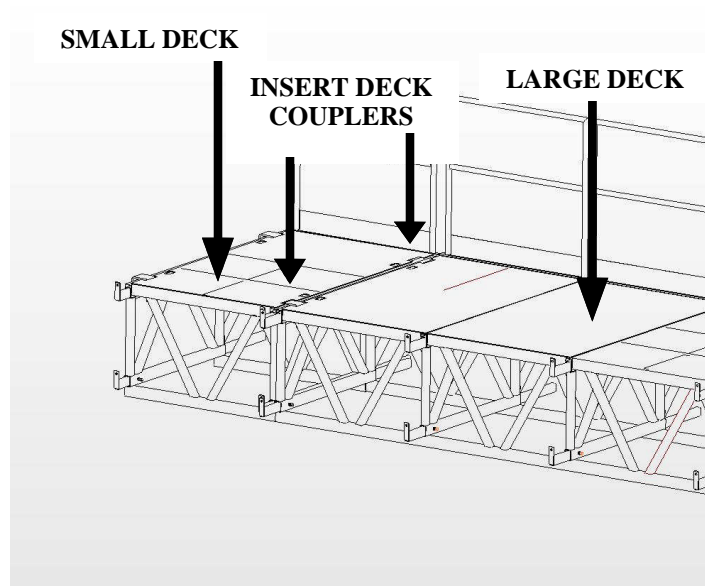

### **Bolt Deck Couplers**

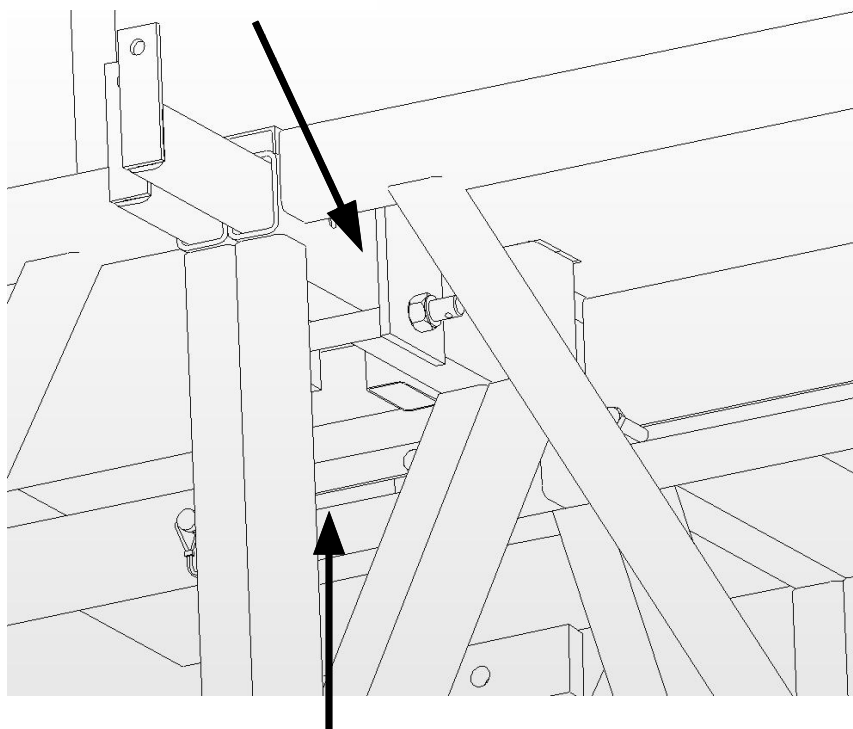

**Slide Bar and Lock Pin**

**Connect Cantilever Decks using Deck Couplers. Slide bar from connecting deck and lock with Lock Pin.**

**Both sides of Power Unit must be evenly balanced. If not connecting decks to both sides then appropriate weight should be applied to opposite side.**

**If using more Cantilever Decks on one side then the other, it is necessary to off set the difference in weight by setting 50% of the weight of the Deck and material on opposite side of the Power Unit as close to the tower as possible or beyond.**

Bridge Adapters may be attached to Cantilever Decks to connect to Power Units together. The greatest distance covered by two units is 148 linear feet. This consists of two 24' Power Units with two 16' Cantilever Decks, two 4' Cantilever Decks connected by a 20' Bridge (one 16' Cantilever Deck and two 2' Bridge Adapters).

Slide out Slide Bars on far ends of Cantilever Decks and set fully assembled Bridge on Slide Bars. Pull out Slide Bars with hooks from Bridge Adapters and extend hooks.

When connecting Bridge, the components that make up the Bridges must be deducted from the overall capacity of the Cantilever Decks that the Bridge is connected to. Use the chart below to calculate the weight. The maximum weight that can be set on a Bridge is 3,000#.

Component Name	Deduction (Lb)
4' Deck Extension	850
8' Deck Extension	1250
16' Deck Extension (or Bridge)	2050
2' Bridge Adapter	350

ex. Bridge components

16' Deck	2050#
2' Bridge Adapter	350#
2' Bridge Adapter	350#
<b>Total</b>	<b>2750#</b>

Capacity of Cantilever Deck is 5000# each  
 Two Cantilever Decks (one for each Power Unit that the Bridge is connected to) allows for a 10,000# total capacity.

	10,000# Total Cantilever Deck Capacity
less	2,750# wt. of Bridge Components
	7,250# Total Payload

Bridge Capacity is 5,000# with no more than a total of 7,250# allowed overall.

SEE DIAGRAM ON FOLLOWING PAGE

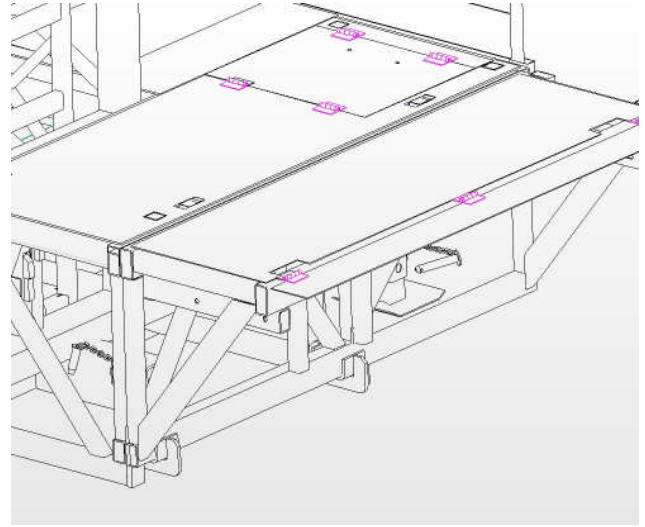

**SET BRIDGE ADAPTER HOOKS ON TO CANTILEVER DECK**

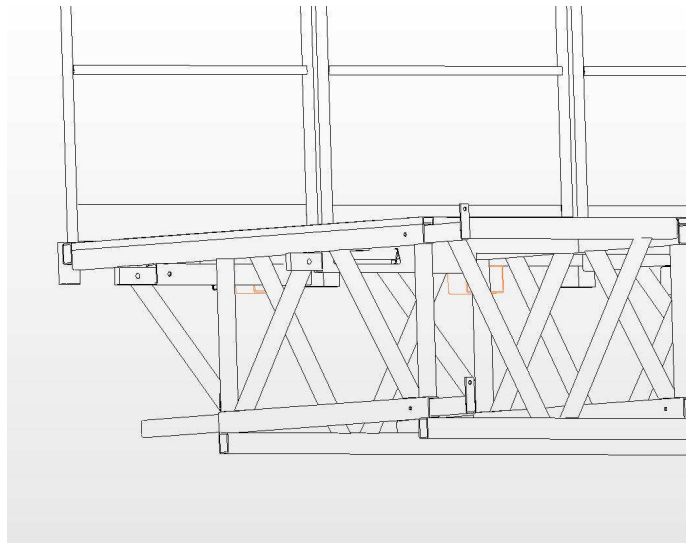

**PULL OUT CANTILEVER DECK SLIDERS OF DECK THAT YOU WANT TO USE FOR BRIDGE**

# CAPACITIES

25,000 Lb total capacity

5,000 Lb total capacity  
Deck capacity

5,000 Lb total capacity  
Deck capacity

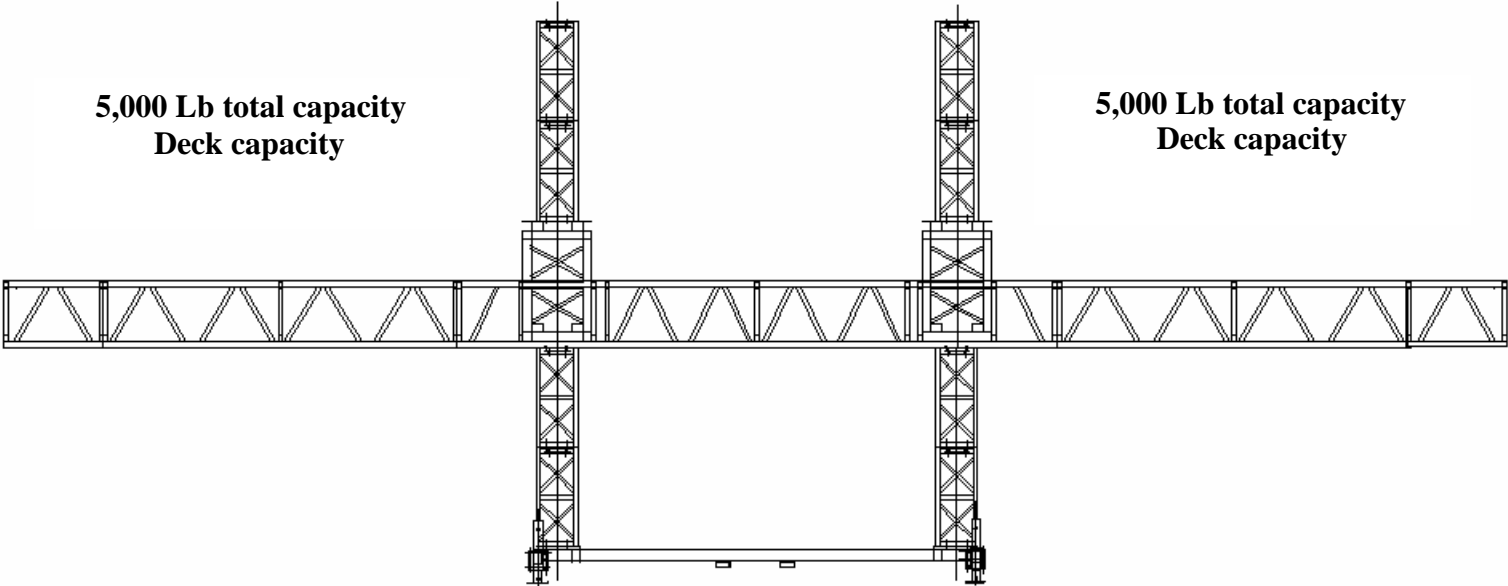

2,750 Lb Weight of Bridge Components  
With a 3,000 Lb Capacity

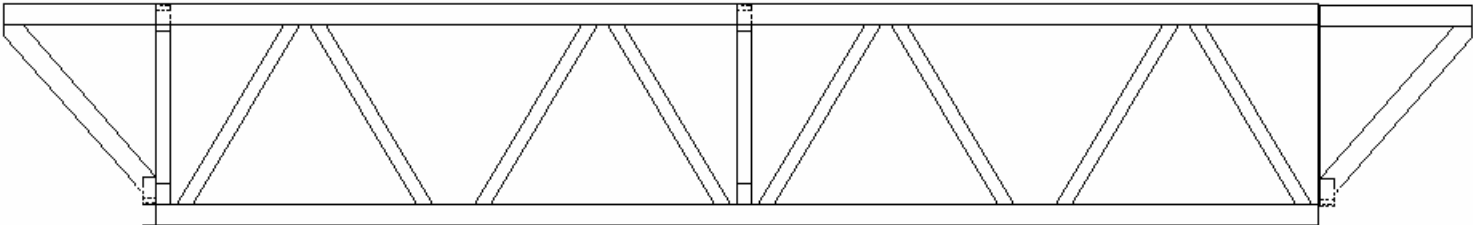

7,250 Lb Overall Total Capacity Allowed  
On Cantilever Decks and Bridge When  
Connected

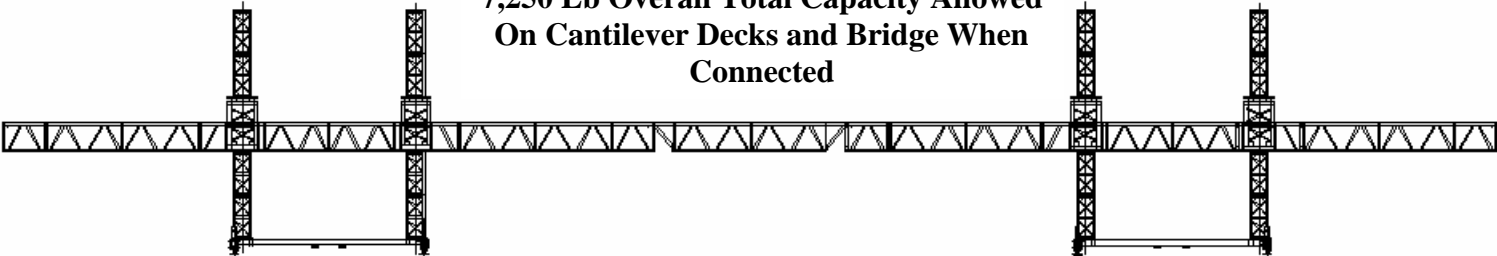

**Insert Deck Couplers through receivers on Bridge Adapters and Cantilever Decks.**

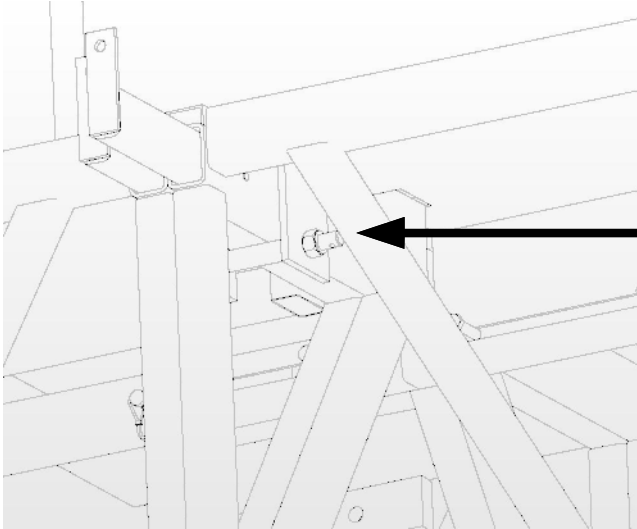
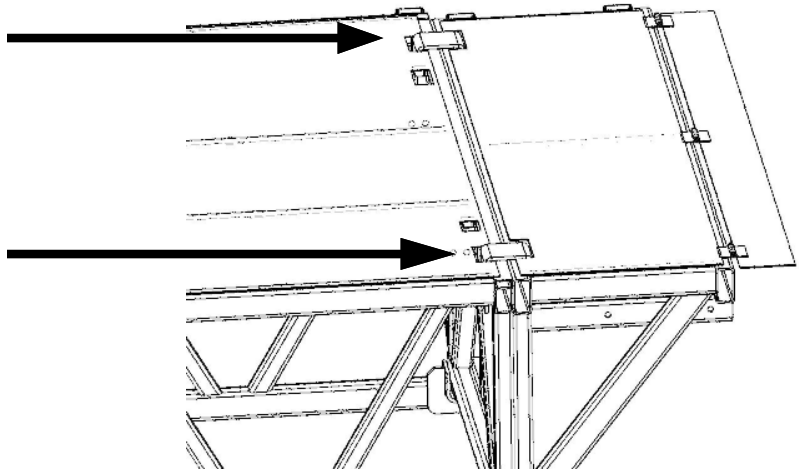

**Bolt couplers**

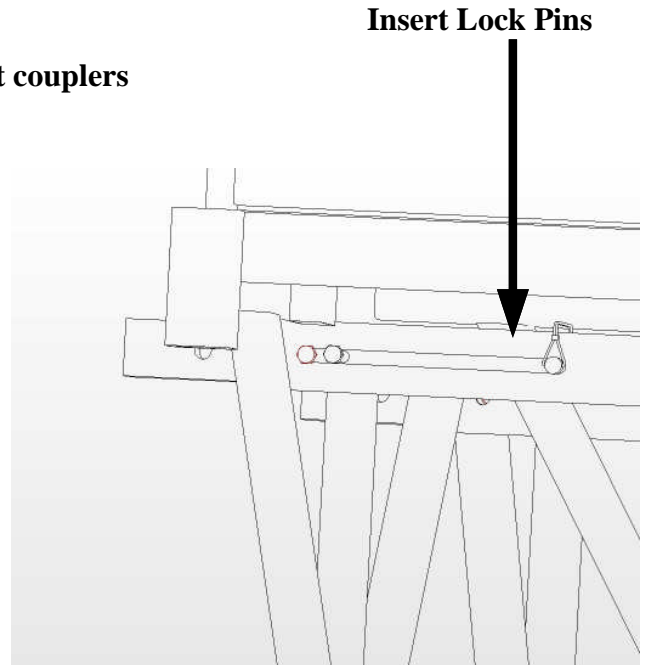

**Insert Lock Pins**

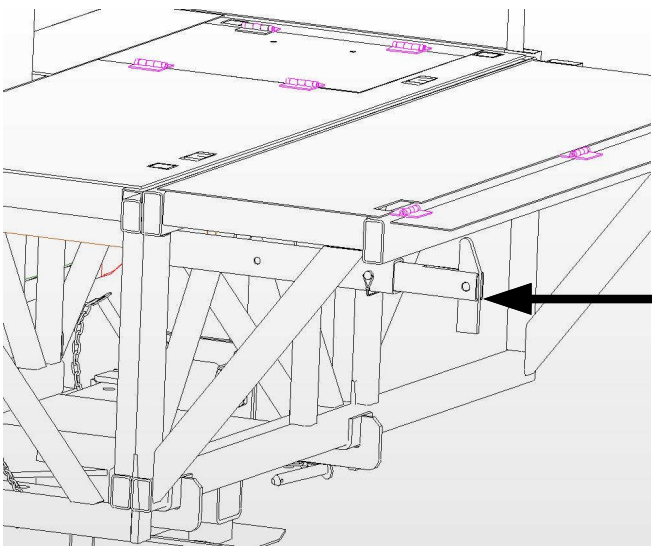

**Extend Bridge Adapter Hooks**

# EZ Scaffold Mast Climber 90 Degree Deck Assembly

Connect 90 degree deck as you would a cantilever deck.

Slide arms from 90 degree deck under mid-deck and secure with 1/2" X 3" pins provided.

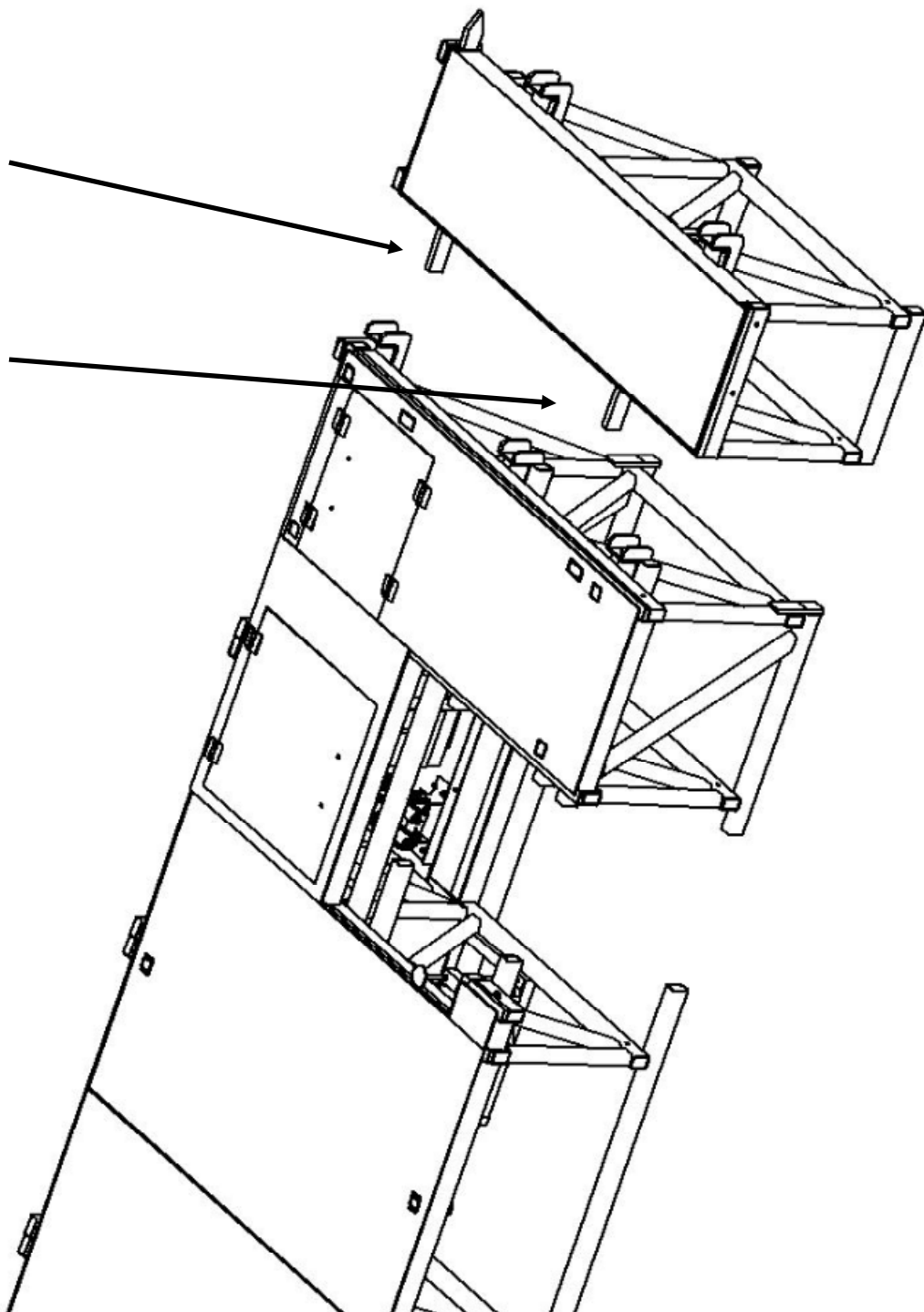



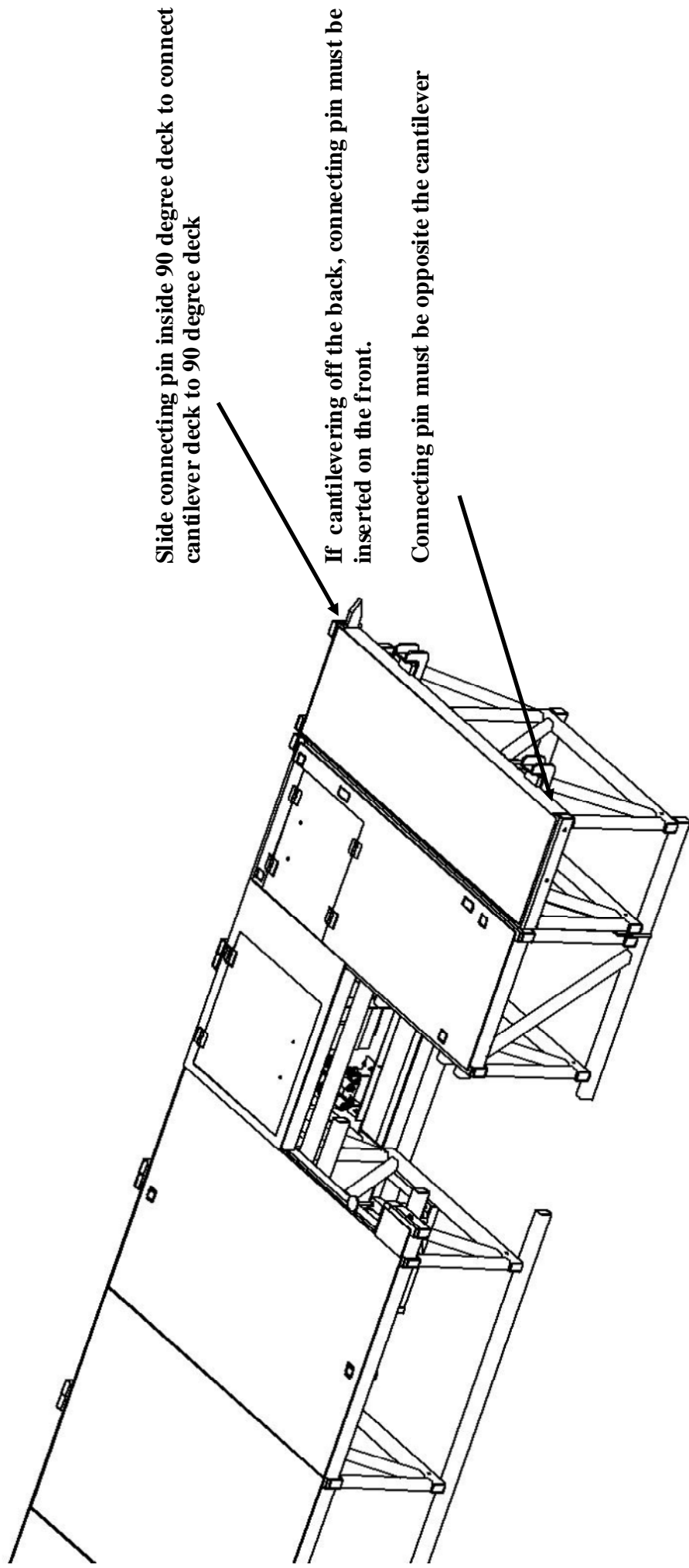

Slide connecting pin inside 90 degree deck to connect cantilever deck to 90 degree deck

If cantilevering off the back, connecting pin must be inserted on the front.

Connecting pin must be opposite the cantilever

**Remove Walkboard and Material and Platform Extensions  
before connecting Cantilever Deck**

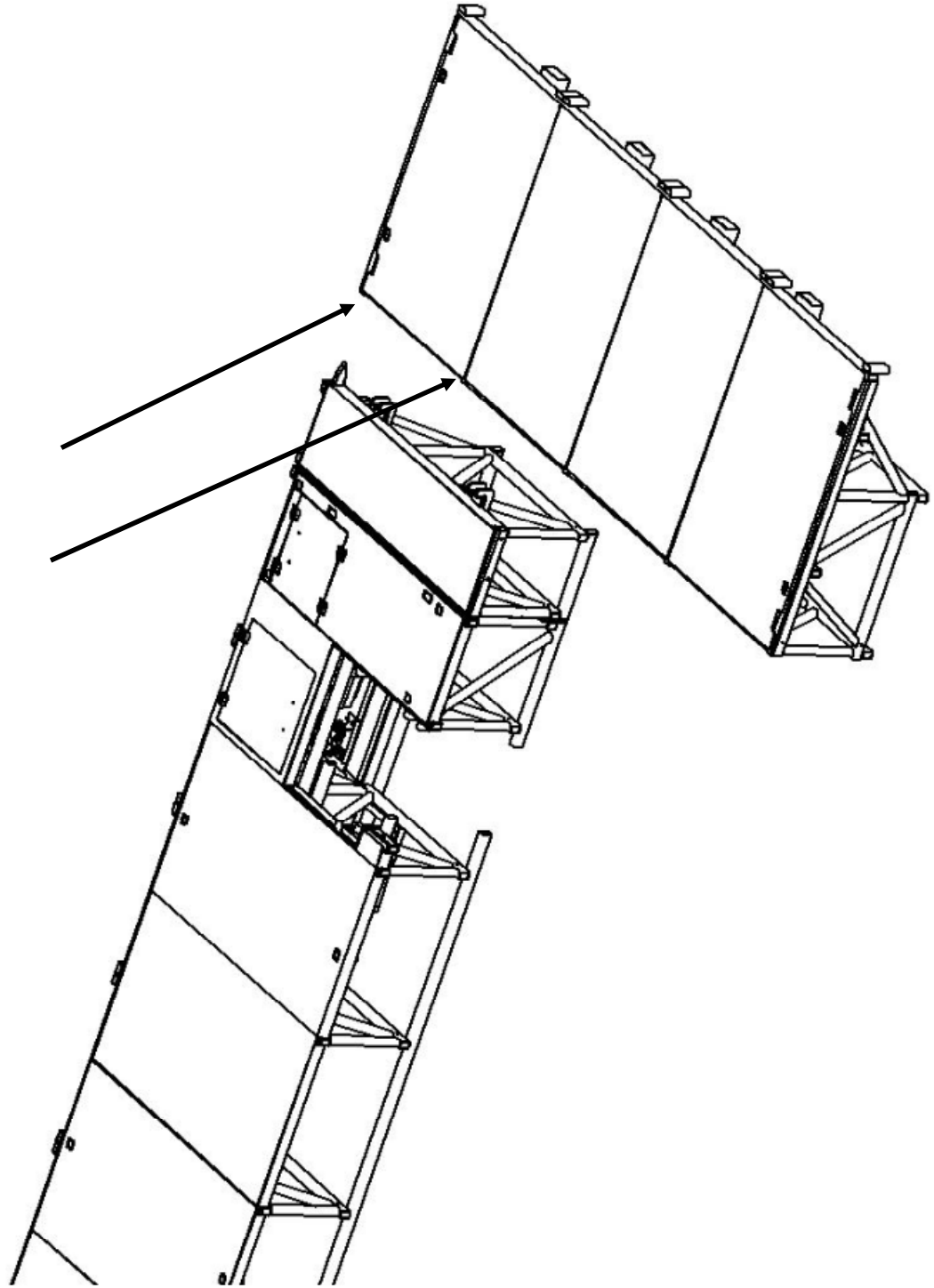

**WARNING: DO NOT USE DECK IF CONNECTING PIN IS NOT IN PLACE AND PROPERLY SECURED. IF YOU ARE NOT SURE ASK!**

Insert Connecting pin in back to cantilever off the front. Insert 1/2" X 3" lock pin to keep bar from backing out.

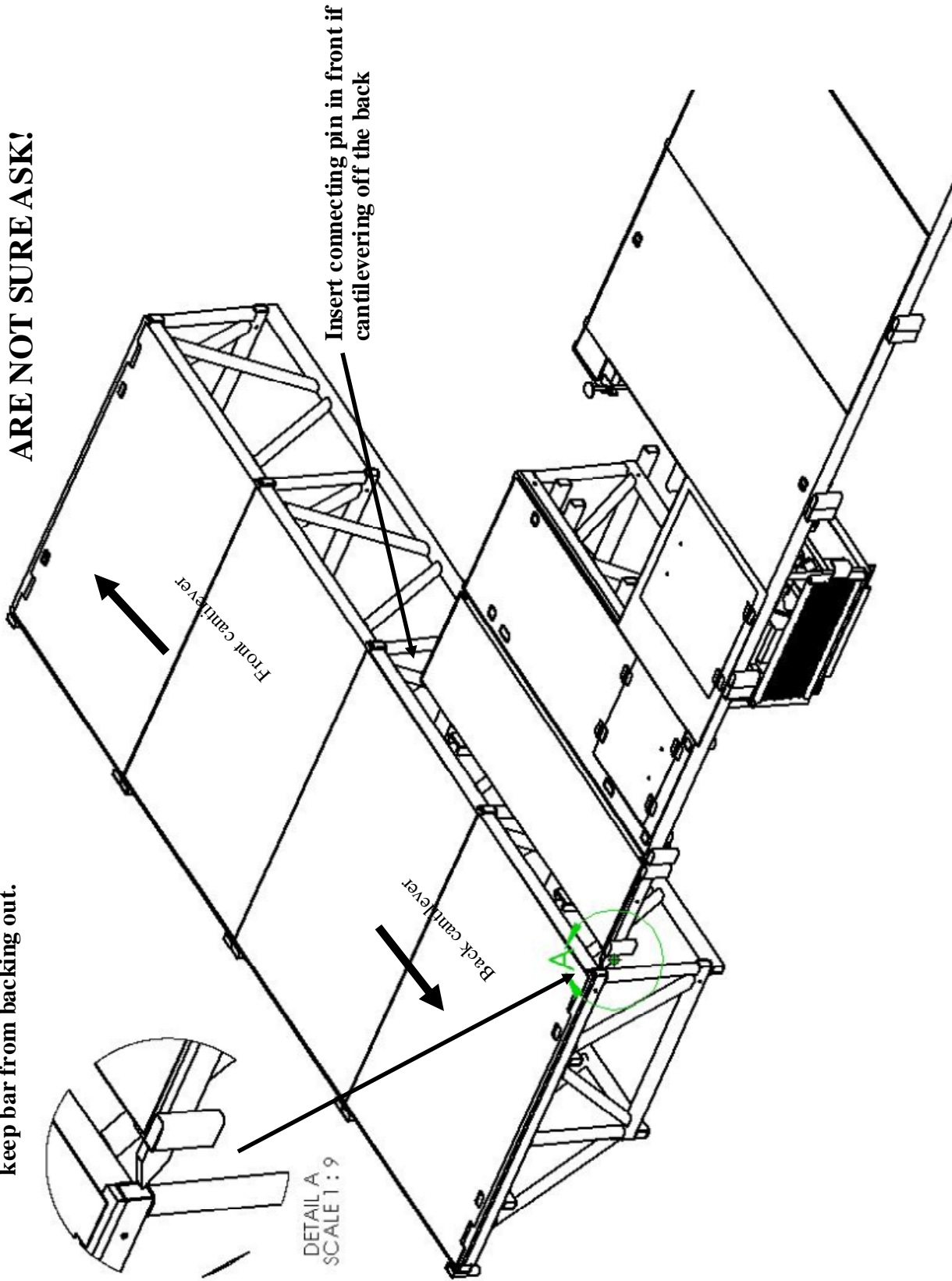

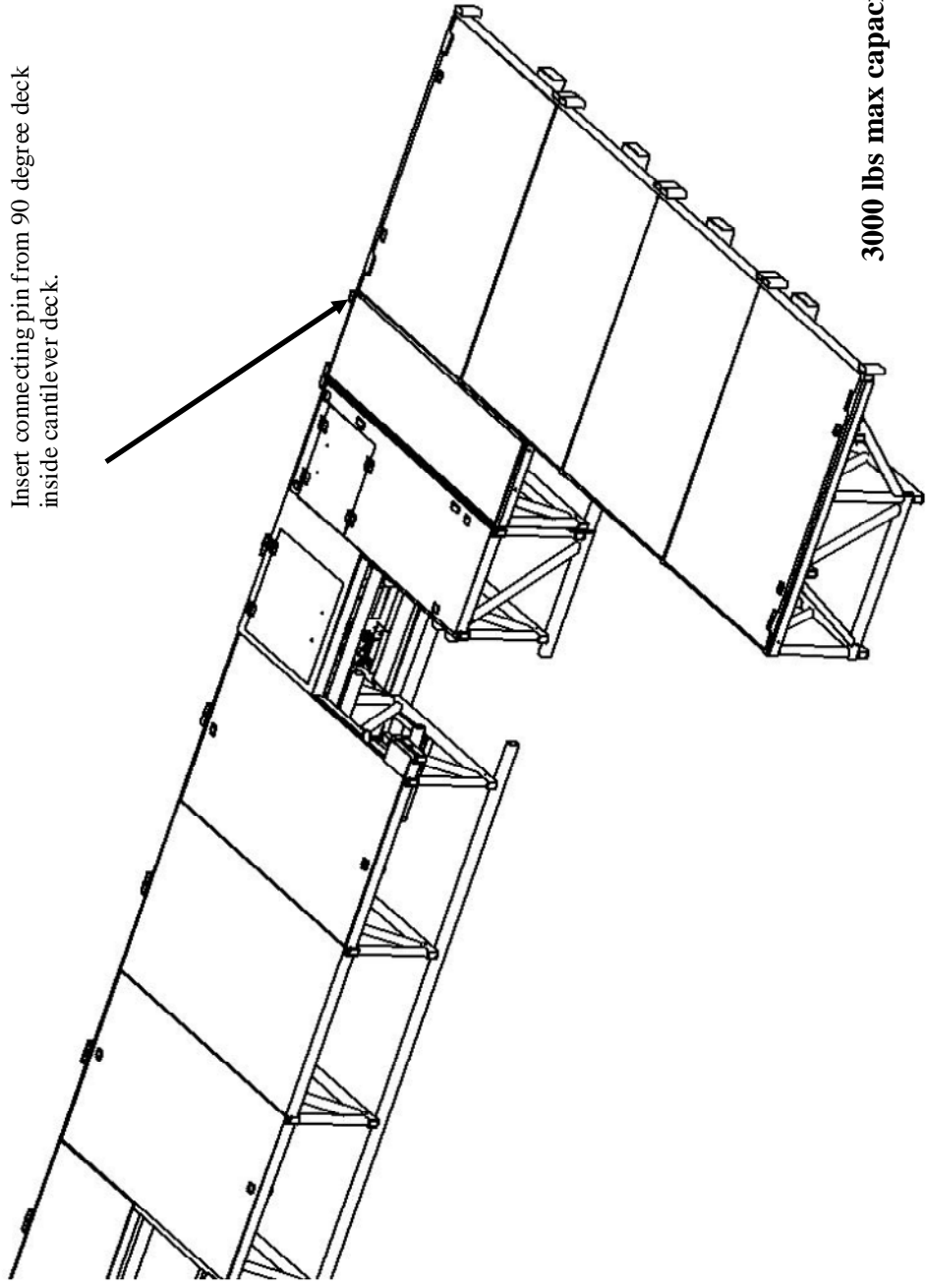

Insert connecting pin from 90 degree deck  
inside cantilever deck.

**3000 lbs max capacity**

**Counterweight  
required consult mfg.**

**A 16' Cantilever Deck may have no more than one  
4' Cantilever Deck on each side.**

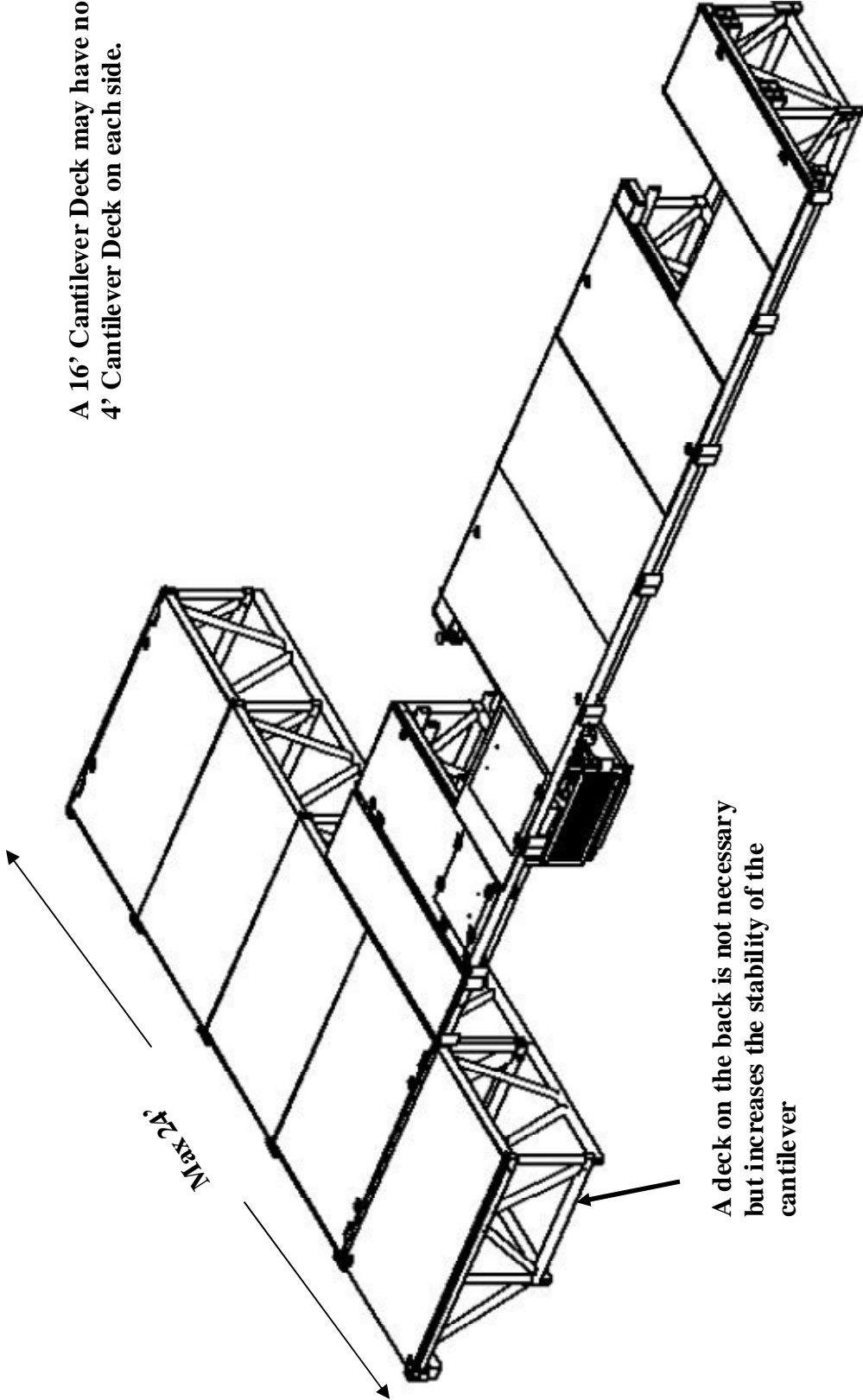

**A deck on the back is not necessary  
but increases the stability of the  
cantilever**

**Guard Panels-** Install Guard Panels to back and end of platform. Install Mason's End Panels to ends of walkboards.

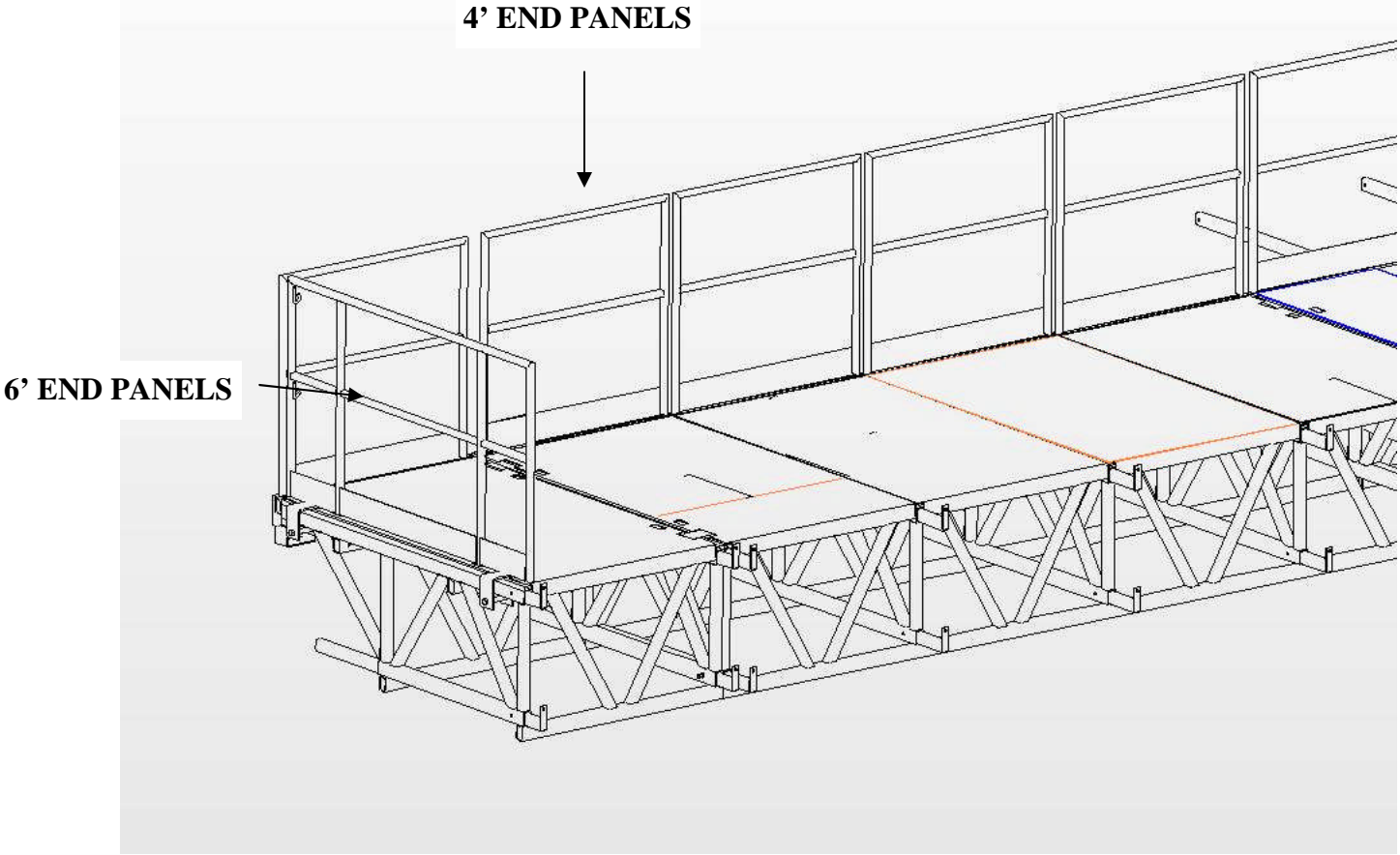

## WALL TIES AND ANCHORS

Install Wall Tie-Offs to every scaffold tower every 20 vertical feet and connect to wall according to following diagram. **MAKE SURE WALL TIES DO NOT INTERFERE WITH BOARD LAP (DO NOT HIT BOARDS WHEN PLATFORM IS PASSING WALL TIES).**

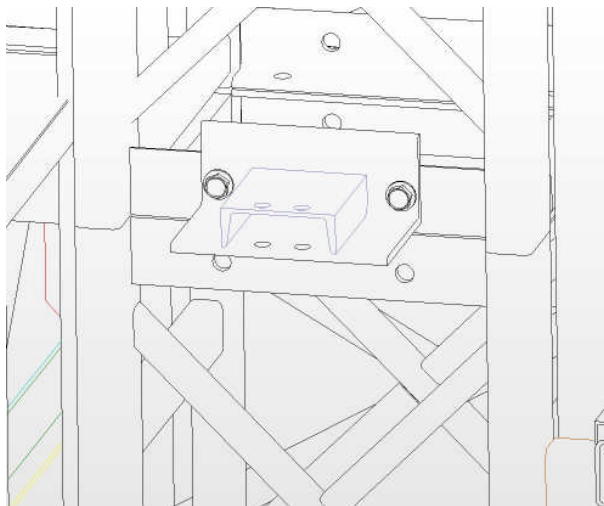
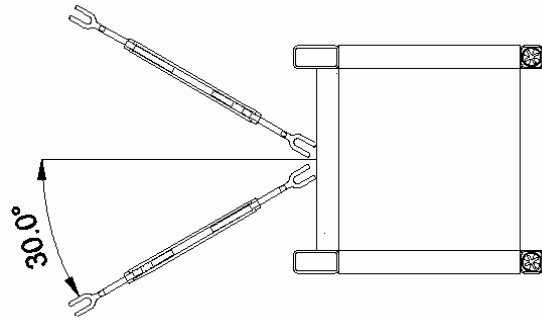

**Attach Wall Tie-Off Bracket**  
with 5/8" flanged bolts and  
serrated locking nuts

**Open carriages allow for wall ties to pass through. Remove Pass Through Plate and any walk boards to allow ties to pass through.**

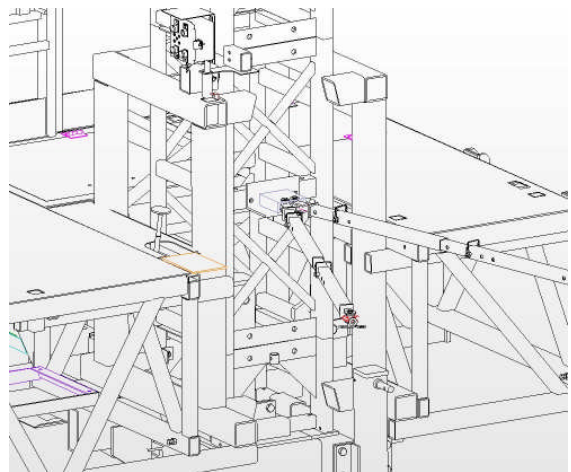

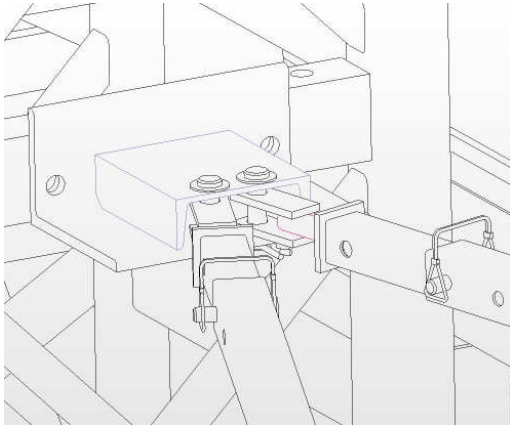

**Attach Tie-Offs to Bracket with cotter pins and washers provided**

**Adjust Tie-offs as necessary. Use 1/2" X 3" Lock Pins provided to lock in place. Tie-Offs may be turned (turnbuckle) for finite adjustments.**

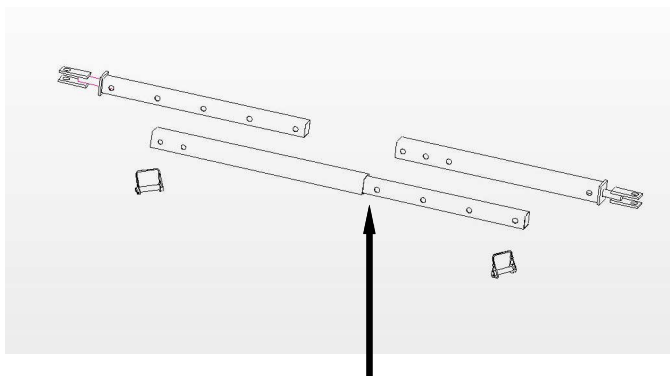
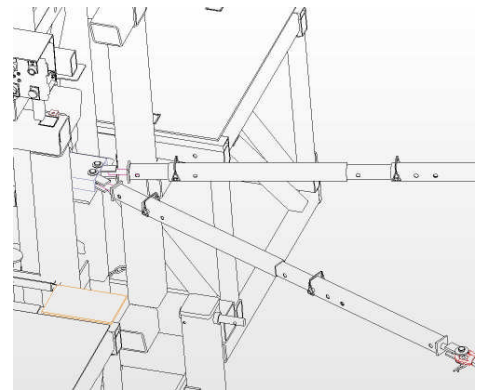

**Use extension in areas where extra reach is needed. (Purchased seperately)**

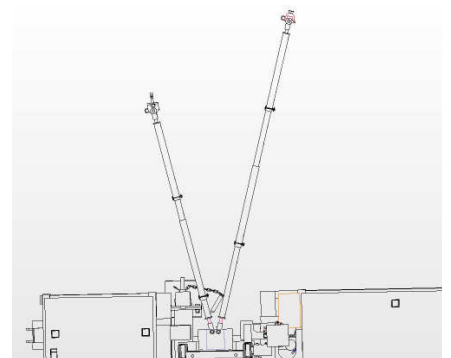



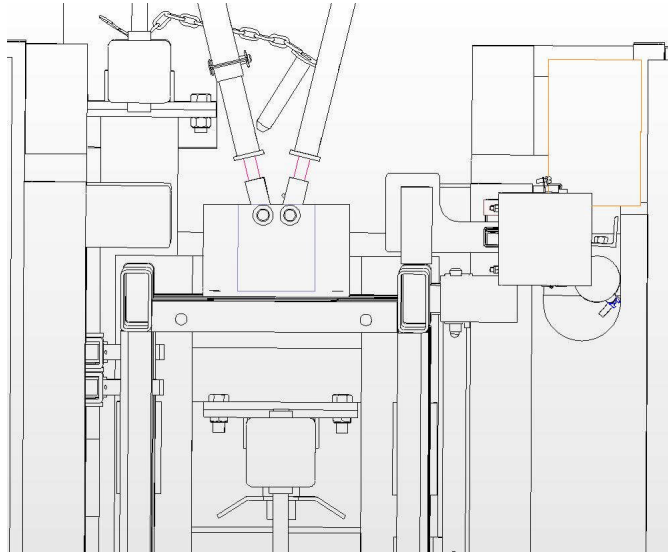

**Tie-Offs may be attached at any cross member with holes provided.**

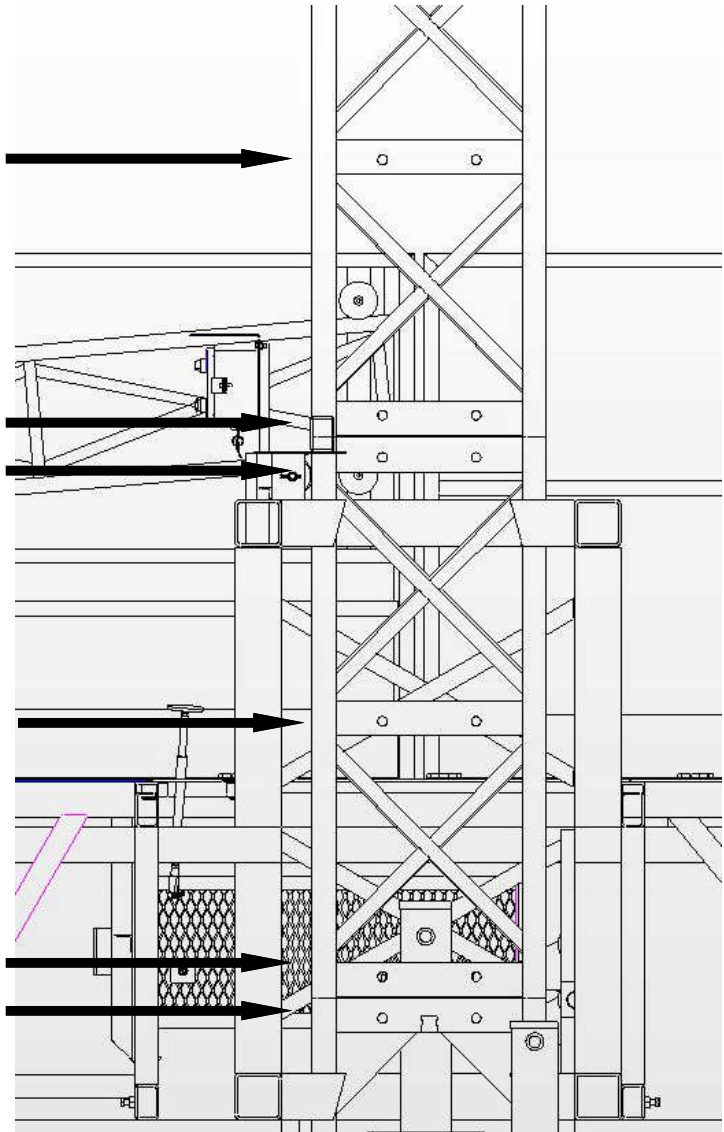

## TYING OFF

A scaffold system is designed to withstand downward forces. Therefore the system is easily affected by *lateral forces* which are side forces that push or pull against the scaffold. For instance high winds or a forklift hitting the scaffold are lateral forces.

Tie off each pair at OSHA recommended intervals.

Scaffold ties may be placed closer together depending on the following:

Other standards - e.g., the Alberta Occupational Safety and Health Standards (Canada) require ties to be placed every 15' vertically and 21' horizontally

-local requirements

-manufacturer recommendations

-environmental conditions such as lateral forces.

Scaffold systems can fall into or away from a structure. Therefore, every tie-in must prevent the scaffold from both push and pull effects. The OSHA scaffold standard states "guys, ties, and braces shall be installed at locations where horizontal members support both inner and outer legs".

EZ Scaffold Mast Climbers should be tied off when the working height is four times the minimum dimension of the base. Freestanding height should be no more than 40' or less depending on job site conditions determined by competent person and/or local requirements. Tie-offs should begin at a maximum of 20' high and continue at a maximum of every 20' (approximately) at each tower.

In cold climates, many scaffold systems are used as skeletal support for winter weather enclosures. Heavy winds push against the poly-plastic that is used to enclose the working environment. The new OSHA standards do not specify what wind speeds might create dangers for a scaffold user. However, it does require the competent person to decide when windy weather is creating an unsafe condition for workers on the scaffold. E Z Scaffold recommends that each tower be tied off at a maximum of 10' (approx).

Tiebacks shall be secured to a structurally sound anchorage on the building or structure. Sound anchorages include structural members, but do not include standpipes, vents, other piping systems, or electrical conduit. Anchors must be capable of tensile or compression strength of 3000 lbs.

## ACCESS PLATFORM

**Mast Towers meet OSHA specifications to climb for access. Access Platform must be in operation for legal access to platform. Rest Platforms must be installed every 35 feet high.**

**Remove transportation posts from access decks and install long Access Platform Posts at each corner.**

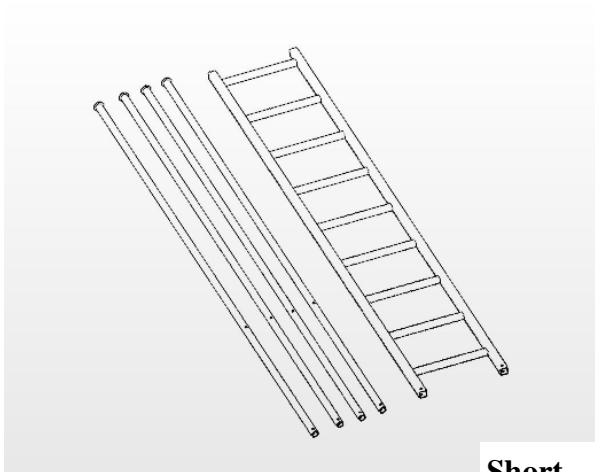
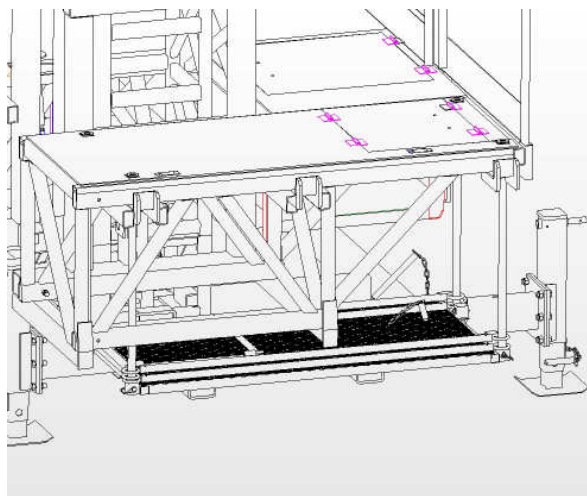

**Parts consist of Access Ladder, three long Access Posts to each corner and one short Access Post installed at corner closest to tower on wall side.**

**Short post installed at wall side corner closest to**

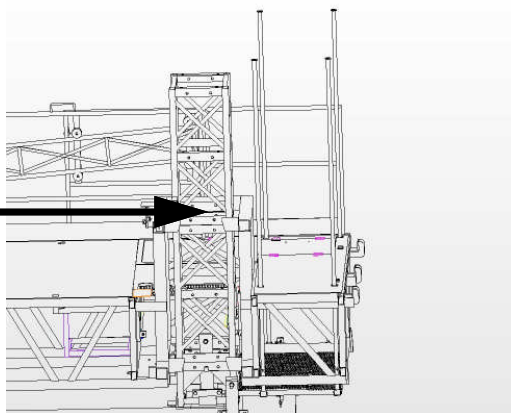

**Access Ladder Installation** - Install Access Ladder through Platform Access Trap Door and pin with Lock Pins.

Access Platform from tower by using trap door on Access Platform and then climb Access Ladder through Platform Trap Door.

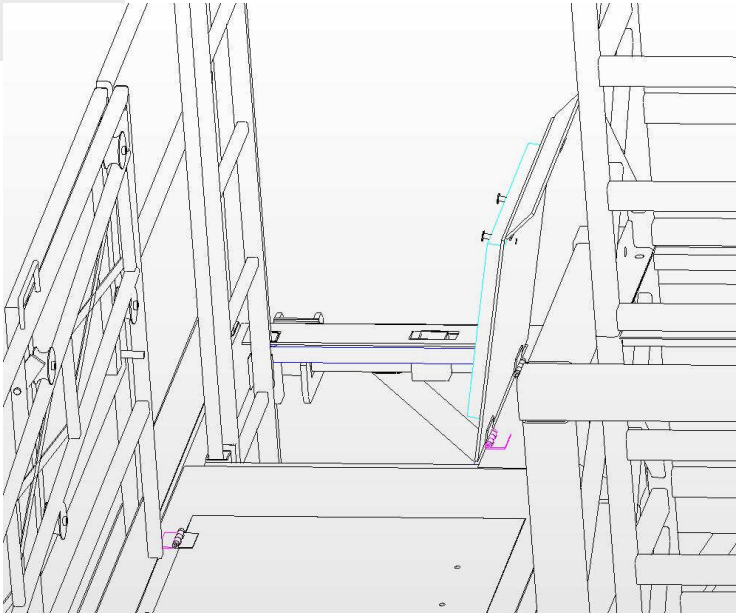
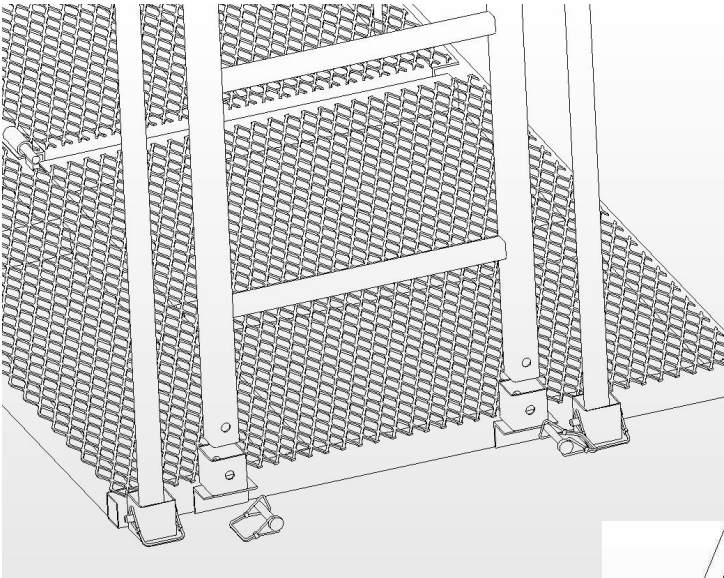
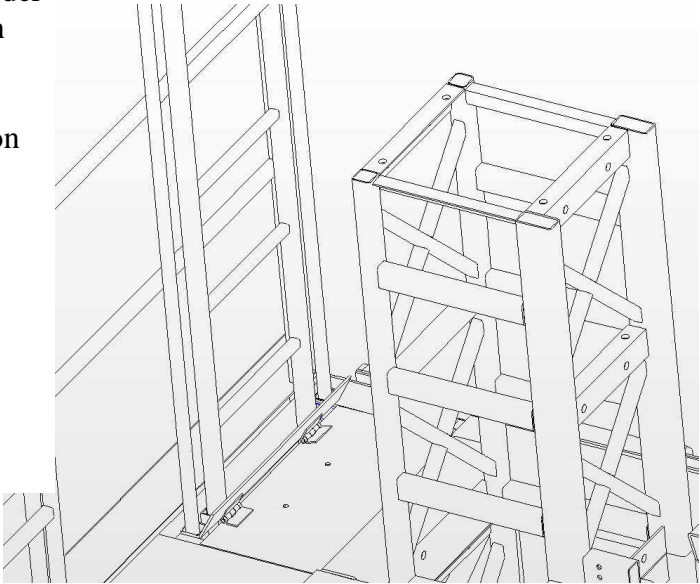

## Daily Check List

The following list is intended to provide workers using scaffolds basic information on identifying and correcting some potential hazards in the erection and use of adjustable climbing scaffold. It may be used as a prerequisite for builders and workers who are assigned as the competent scaffold person by the employer. However, it is not intended to provide information for scaffold system builders, unless the program is used with advanced scaffold training provided by factory approved instructors. Further training is needed for those workers who erect and dismantle scaffolds or are assigned the responsibilities of a competent person at the work site.

OSHA now requires every worker on a scaffold to recognize hazards and know the safe working conditions that should exist. It is no longer the sole responsibility of the erector and dismantler of the scaffold system to correct unsafe conditions. Some examples of unsafe conditions include:

- 1. Ground Conditions: Settling of the ground beneath the unit may occur. Erosion can cause a dangerous situation. Check that all supports are loaded and mud sills, if used, are in place. More frequent checks may be required under conditions of rain, freeze or thaw.**
- 2. Level. Check that the unit remains level. More frequent checks may be required under conditions of rain, freeze or thaw. Make sure all pins are in place in Outriggers and Jacks.**
- 3. Straight Towers. Visually check for straightness of towers. Make sure all wall ties are in the proper place and correctly installed.**
- 4. Guard Panels: All Guard Panels, End Panels, and Mason's End Panels should be in place.**
- 5. Hydraulic Oil level: Check oil level at beginning of each shift.**
- 6. Straight ladder rungs: Check all towers for any damage. Consult competent personnel before removing and/or continuing to use.**
- 7. Make sure all scaffold plank are in place, with proper spacing and overlap.**

Personnel working with/on scaffolds or supervising those who do, need to be aware of these situations as well as read OSHA scaffolding standard 29 CFR Part 1926 and all safety and installation instructions provided by manufacturer.

This should be added to your daily check list before using scaffold.